



## Waste-to-energy plant

# TAS I/S, line 5

# Kolding, Denmark



### Contract on waste-fired boiler to TAS I/S

Babcock & Wilcox Vølund have supplied a waste-to-energy line for TAS I/S (Trekantområdets Affaldsselskab I/S) situated in Kolding, Denmark. The new plant went into hot operation in spring 2007 and was officially opened on 30 August 2007.

TAS I/S is a municipality company owned by eight municipalities in the growth region 'Trekantsområdet' in Denmark. The two lines, line 2 and line 5, produce heat for 15,000 households and electricity for 10,000 households.

*The new line is equipped with the new advanced combustion technology developed for fuels with high heating values. The core elements are the water-cooled DynaGrate® and water-cooled wear zones.*



# Combined heat and power plant TAS, Denmark

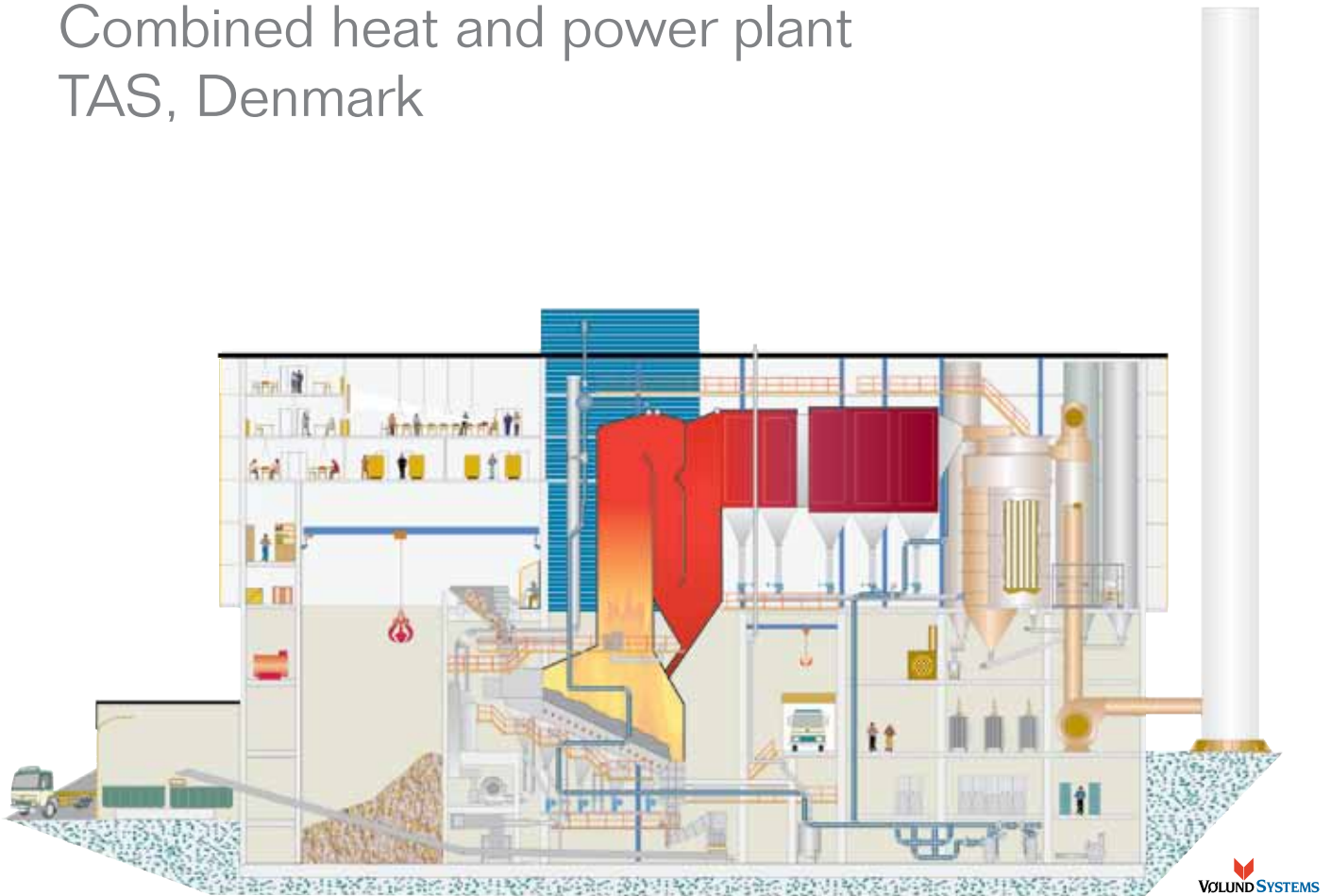

## **BWV's scope of supply**

The new plant is designed for high and/or fluctuating heating values. It is equipped with a modern three-pass Vølund boiler with a horizontal convection part for the production of hot water. The grate system is a one lane water-cooled DynaGrate®. The wear zones are water-cooled as well.

The new line has a nominal capacity of 10 tonnes of waste per hour at a heating value of 11 MJ/kg and a maximum waste throughput of 12.5 tonnes per hour. The thermal efficiency is 86.5 % and the district heating output is 26 MW.

## **Proven technology for waste with high heating values**

In Europe there is an increasing market demand for technologies capable of burning waste with high heating values. In Scandinavia it is common to burn quite big fractions of industrial waste as for example demolition wood and different types of biomass. In order to meet the periodically very high heating values Babcock & Wilcox Vølund have developed new combustion technology adapted to high or fluctuating heating values. The core technologies are:

- Water-cooled combustion grate
- Water-cooled wear zones above the grate.

One of the unique developments is the integrated water-cooling system. The cooling water flow is led from each grate bar through two concentric pipes placed inside the shaft. The individual grate bars are connected in series. The water is also returned from the grate bars through the piping system. The cooling system is well integrated and protected in the steel shaft.

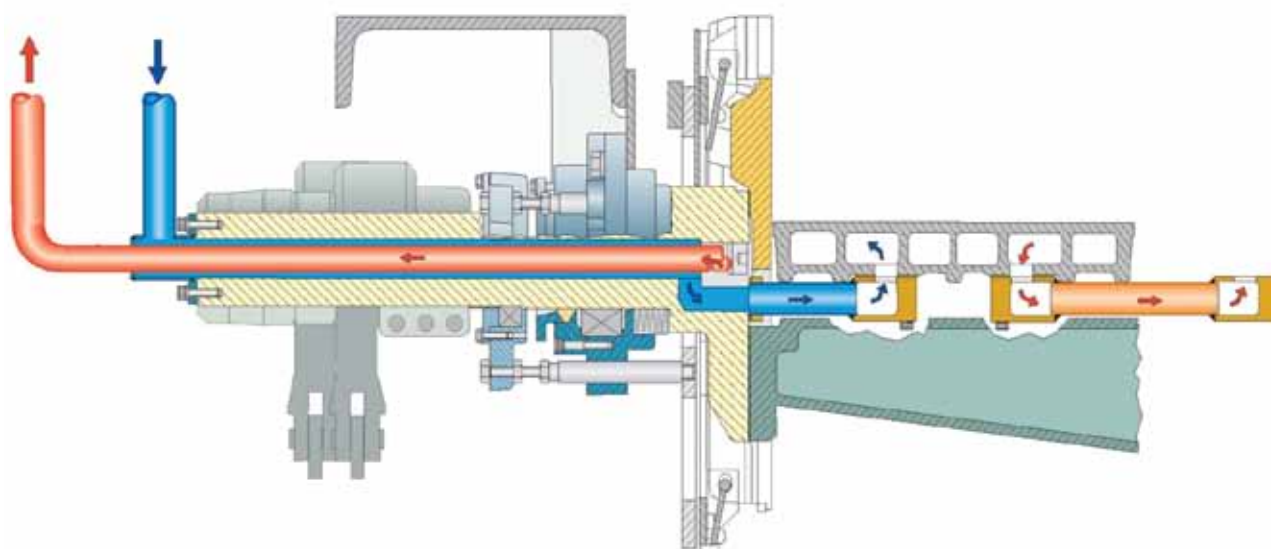

### DynaGrate®

DynaGrate® has been under continuous improvement for over 30 years. The latest version of the grate is water-cooled and is a successful result of our dedicated research and development efforts. The grate is distinguished by its suitability for high calorific fuel. The water-cooled grate also offers full integration with the air-cooled version, providing complete freedom within the grate area, be it air-cooled, water-cooled, or both.

DynaGrate® provides a number of process advantages, such as:

- Good mechanical break-up of the waste layer on the grate, resulting in excellent agitation of the fuel bed and superior combustion conditions.
- An advanced combustion control system, efficient air distribution and mixing of waste ensure a controlled and efficient combustion. This leads to very low TOC values in the bottom ash and a high ash quality.
- The slow and continuous grate movement produces only small quantities of dust and fly ash.
- No physical contact between movable grate parts. This reduces wear-and-tear as well as the mechanical forces to which the grate is exposed during operation.
- The driving mechanism is situated outside the furnace, i.e. the mechanism is not exposed to aggressive environment. The design provides easy access for maintenance.



Above the grate: The grate for the waste-to-energy plant TAS in Kolding



Below the grate: No flex tubes below the grate

### The new generation: The water-cooled grate

The water-cooled grate provides the same process and mechanical advantages as the air-cooled version. Furthermore, it has the advantage of lower maintenance cost, reduced amount of grate riddling and less problems with molten metal. The primary combustion air can be controlled without consideration for the cooling of the grate bars. Moreover, low excess air results in less flue gases, thereby reducing the stack energy loss.

### Integrated cooling system in the shaft

Standard steam hoses are used for connecting the water from the fixed piping system outside the furnace to the moving shafts. The hoses are placed outside the furnace in order to avoid exposure to hot ashes, molten tin, aluminium, etc. that could damage the hoses. As a result of this design, all types of flexible connections are avoided under the grate. This unique design results in a very reliable water-cooled combustion grate that ensures the annual operating hours.

Plant design data		
Process parameter	Values	Units
Nominal capacity, waste	10	t/h
Max. continuous capacity	12.5	t/h
Pressure	10	Bar
Hot water	180	°C
Feed water temperature	130	°C
District heating output (max)	28	MW
Boiler outlet flue gas temperature	160	°C
Thermal efficiency	86.5	%
Combustion efficiency		
Bottom ash	2/3	TOC/LOI %

Flue gas values		
Out of boiler		
CO	25/50	mg/Nm <sup>3</sup>
TOC	5/10	mg/Nm <sup>3</sup>
NO <sub>x</sub>	200/400	mg/Nm <sup>3</sup>
NH <sub>3</sub>	10	mg/Nm <sup>3</sup>

All values refer to 11% O<sub>2</sub>.

The emission values refer to daily average/half-hourly value.

The plant limit values comply with the EU directive on waste incineration.

### Babcock & Wilcox Vølund A/S

Falkevej 2 • DK-6705 Esbjerg Ø • Denmark • Tel: +45 76 14 34 00 • Fax: +45 76 14 36 00

We have branch offices in Aarhus and Glostrup/Copenhagen, Denmark.

The information contained herein is provided for general information purposes only and is not intended or to be construed as a warranty, an offer, or any representation of contractual or other legal liability. Babcock & Wilcox Vølund A/S is 100% owned by Babcock & Wilcox Power Generation Group, Inc. in Barberton, Ohio, USA. © 2010 Babcock & Wilcox Vølund A/S. All rights reserved.