

Waste-to-energy plant

L90

Esbjerg, Denmark



At the beginning of 2001 L90 made a contract for a large new waste-to-energy plant in the city of Esbjerg. L90 is a union of 35 municipalities with more than 600,000 inhabitants in the mid Jutland area and was formed with the purpose of owning and operating the new plant.

The fuel is domestic and industrial waste, and the plant has a design capacity of 24 t/h at a heat value of 11 MJ/kg, corresponding to 180,000 t/year. This is one of the largest plants built in Denmark.

The plant features the latest technological advances in the field of waste incineration as regards both boiler and combustion technology and emissions to air and water. The overall thermal efficiency is 89%.



Combined heat and power plant L90, Denmark

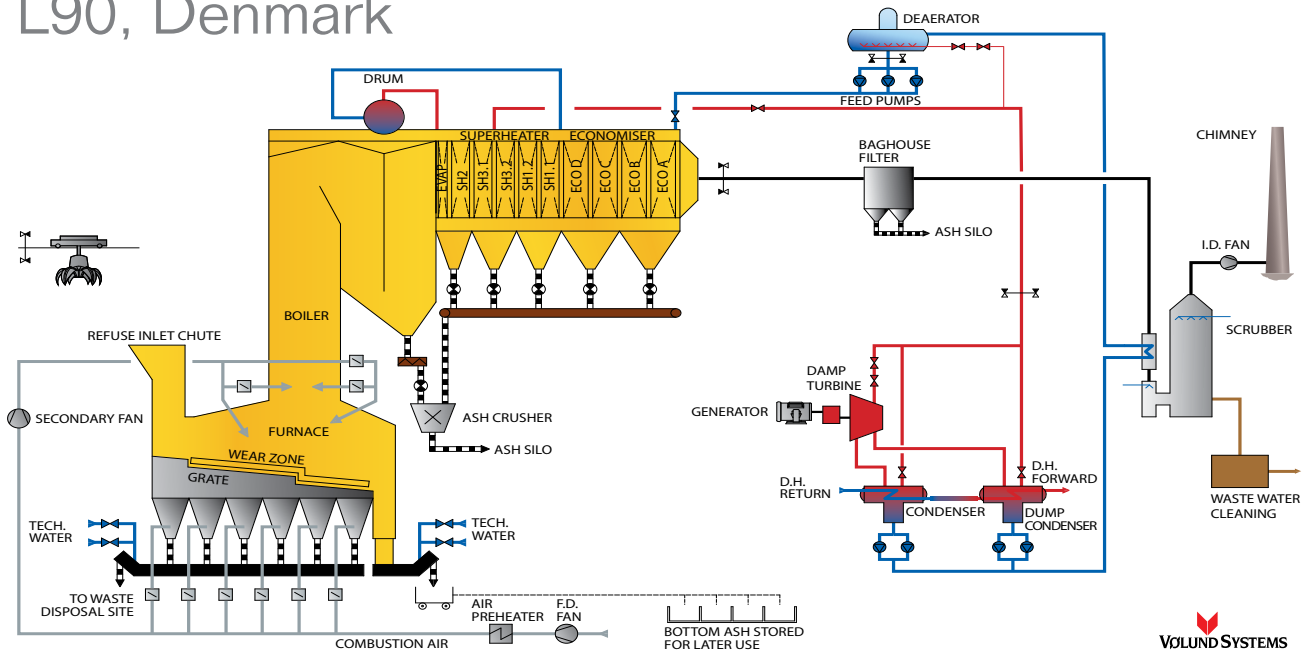

VØLUND SYSTEMS

Babcock & Wilcox Vølund A/S (BWV) was awarded the contract for the supply of the complete incinerator with boiler and control system. The boiler generates high pressure steam for a turbine of 16.5 MWe, and the remaining heat is utilized for district heating in the local district heating network.

BWV scope of supply

Complete incinerator with waste crane, feed chute, feed grate and five-section combustion grate, combustion air system, auxiliary burners, ash conveyors for slag and fly ash from the boiler hoppers, feed water pumps with controls. Complete steam boiler with boiler drum, vertical furnace with empty passes (pendent structure) followed by economiser and superheater sections made of vertical tubes (standing structure) with cleaning arrangements. Pressurized air and SNCR system. Complete control equipment for the whole incineration plant excl. software for turbine, flue gas cleaning, etc.

New technology

The furnace is provided with cooled wear zone sections at both sides. Furthermore, the furnace and the first boiler pass are clad with Inconel (a very wear and heat resistant alloy) welded directly onto the boiler tubes.

Thus the need for refractory, which requires annual inspection and frequent repairs, is eliminated. Advanced Combustion Control (ACC) technology with camera monitoring of the combustion is installed. This makes it possible to control the air supply to the grate in a network, which ensures homogenous combustion throughout the grate.

Plant Data	
Nominal capacity, waste	24,0 t/h at 11,0 MJ/kg
Max. continuous capacity	26,4 t/h at 10,5 MJ/kg
Steam data	42 bar, 400°C
Steam generation, nominal	25.13 kg/s
Steam generation, max. cont.	26,37 kg/s
Feed water temperature	130°C
Electricity output	16,5 MWe
District heating output	46 MW

Flue gas guarantees: Out of boiler	
Dust	4,0 g/Nm ³
CO	50 mg/Nm ³
NOX	200 mg/Nm ³
NH ³	10 mg/Nm ³
Dioxin	5 ng/Nm ³

All values refer to 11% O₂, dry gas.

Flue gas values refers to daily averages. For dioxin 6-8 hours.

The plant limit values comply with the EU directive on waste incineration.

Babcock & Wilcox Vølund A/S

Falkevej 2 • DK-6705 Esbjerg Ø • Denmark • Tel: +45 76 14 34 00 • Fax: +45 76 14 36 00
We have branch offices in Aarhus and Glostrup/Copenhagen, Denmark.

The information contained herein is provided for general information purposes only and is not intended to be construed as a warranty, an offer, or any representation of contractual or other legal liability. Babcock & Wilcox Vølund A/S is 100% owned by Babcock & Wilcox Power Generation Group, Inc. in Barberton, Ohio, USA. © 2010 Babcock & Wilcox Vølund A/S. All rights reserved.